

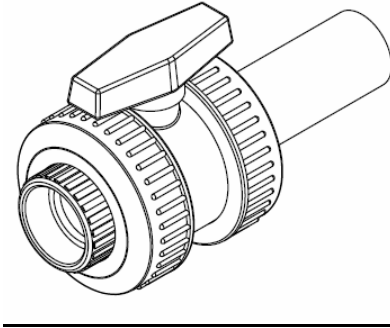

6400 Corporate Avenue  
Portage, MI 49009  
Ph: 269/323-2495 Fax: 269/323-0630  
www.colonialengineering.com

## HP Series Full Block® True Union Ball Valve / PVC Ball Valve with HDPE Spigot End Connector x PVC Socket



### OPERATION, INSTALLATION, & MAINTENANCE INSTRUCTIONS

**Operation:** Quarter-turn of the handle to open or close valve. Standard 2" operating nut is available separately for down-hole service.

#### **Prior to Installation:**

PLEASE READ THE FOLLOWING INFORMATION PRIOR TO INSTALLING AND USING COLONIAL VALVE VALVES, STRAINERS, FILTERS, AND OTHER ASSOCIATED PRODUCTS. FAILURE TO FOLLOW THESE INSTRUCTIONS MAY RESULT IN SERIOUS INJURY.

1. Colonial Valve guarantees its products against defects in material and workmanship only. Colonial Valve assumes no responsibility for damage or injury resulting from improper installation, misapplication, or misuse of any product.
2. Colonial Valve assumes no responsibility for damage or injury resulting from chemical incompatibility between its products and the process fluids to which they are subjected. Compatibility charts provided in Colonial Valve literature are based on ambient temperatures of 70°F and are for reference only. Customer should always test to determine application correctness.
3. Consult Colonial Valve literature to determine operating pressure and temperature limitations before installing any Colonial Valve product. Note that the maximum recommended fluid velocity through any Colonial Valve product is eight feet per second. Higher flow rates can result in possible damage due to water hammer effect. Also note that maximum operating pressure is dependent upon material selection as well as operating temperature.
4. Colonial Valve products are designed primarily for use with non-compressible liquids. They should NEVER be used or tested with compressible fluids such as compressed air or gas.
5. Temperature effect on piping systems should always be considered when the systems are initially designed. Piping systems are required to be designed and supported to prevent excess mechanical loading on Colonial Valve equipment due to system misalignment, shock, vibration, weight, and the effects of thermal expansion and contraction.
6. Trench depth is also an important consideration in freezing climates. Installing the pipe deeper gives it more protection against frost. Where possible, all the pipe, valves and fittings should be installed below the soil frost line.
7. Do not attempt to meter or throttle a ball valve. The valve is to be kept in the full-open or full-closed position.

#### **VALVE ASSEMBLY, AND JOINING WITH HDPE PIPE (DR 11):**

First, assemble HDPE Spigot End to valve. Be sure that the union nuts are hand-tight. Spigot end should be seated against face o-ring of valve body. To check for tightness, make sure the end piece cannot turn or rotate, but is in a fixed position after tightening the union nuts.

After joining the Spigot End to the valve, place the valve body in position. Be sure that the valve is installed in the proper direction, per the Flow arrow indicated on the valve body. Spigot end is to be joined to HDPE pipe using standard butt fusion equipment, electro-fusion couplings, or compression adapters, following equipment manufacturers' recommendations.



6400 Corporate Avenue  
Portage, MI 49009  
Ph: 269/323-2495 Fax: 269/323-0630  
www.colonialengineering.com

### **SOCKET CONNECTION: PVC**

Socket end connections are manufactured to ASTM D2467 (PVC) and F-439 (CPVC). Solvent cementing of socket end connections to pipe should be performed per ASTM specifications D2855-87. Cut pipe square. Chamfer and deburr pipe. Surfaces must be cleaned and free of moisture, oil, dirt and other foreign material. Remove Union-nuts and end connectors from valve body. Slide Union-nuts, with threads facing valve, onto pipe to which the end connector is to be cemented. Apply primer to inside socket surface of end connector. Never allow primer or cement to contact valve ball or end connector o-ring sealing surfaces, as leaking may result. Use a scrubbing motion. Repeat applications may be necessary to soften the surface of the socket. Next, liberally apply primer to the male end of the pipe to the length of the socket depth. Again apply to the socket, and without delay apply cement to the pipe while the surface is still wet with primer. Next apply cement lightly, but uniformly to the inside of the socket. Apply a second coat of cement to the pipe, and assemble the end connector to the pipe, rotating the end connector 1/4 turn in one direction as it is slipped to full depth on to the pipe. The end connector should be held in position for approx. 30 seconds to allow the connection to "set". After assembly wipe off excess cement. Follow cement manufacturers guidelines for proper "cure-time", based on the pipe size that you are joining.

### **Maintenance:**

#### **ADJUSTMENT FOR SEAT WEAR:**

**CAUTION MUST BE TAKEN WHEN WORKING ON THIS VALVE. THE PIPING SYSTEM MUST BE DEPRESSURIZED. PROPER CARE MUST BE TAKEN. CONSULT M.S.D.S. (MATERIAL SAFETY DATA SHEETS) INFORMATION REGARDING YOUR SPECIFIC APPLICATION.**

In the event that a leak occurs from seat wear, there is no need to remove the valve cartridge from the system. Make sure the system is de-pressurized. With the valve in place, simply close it, and then re-tighten the union nut on the upstream side (the side of the body featuring the word "ADJUST"). This will increase the load of the carrier on the ball, to compensate for seat wear.

**UNION NUT CONNECTIONS: Tighten union nuts with the valve in the OPEN position. All union nut connections for ½-2" plastic valves should be "hand-tight". For valves 2" and larger, a strap wrench or approved union-nut wrench may be used to tighten the nut ¼ turn past hand tight.**

**TO DISASSEMBLE FOR MAINTENANCE: Depressurize and drain the system.** Remove union nuts. Close the valve. Remove the valve body from the system. Pull the locking strip on the "ADJUST" side of the valve. Push out the carrier by pressing on the ball from the opposite side. With the carrier removed, you have access to the seats. The stem can also be removed at this time, after removing the handle. A complete line of repair parts is available.

**Climate conditions:** PVC valves (and pipe & fittings) are pressure rated at 73 deg F, and must be de-rated as operating temperatures increase. Normally, we are referring to the fluid passing through the system, but in this case, we are also talking about the exterior environment. Once plastic pipe, valves and fittings are in a box and / or down hole, away from direct sunlight, they will be closer to ambient, so they can function at their rated pressure.

PVC & CPVC Valves and piping components exposed to direct sunlight can reach temperatures of up to 140 deg F. PVC is fully de-rated for pressure at 140 deg, and can start to mal-form when pressurized. So these components may be damaged and unusable after reaching this rate of heat.

**Avoid storing valves in direct sunlight or very hot areas.  
Avoid leaving valves exposed to sunlight in open trenches  
Allow valves, pipe and fittings to cool and settle before pressurizing them with water.  
Re-check the tightness of the union nuts prior to pressurizing the system.**

These recommendations apply to any thermoplastic pipe, valves & fittings (PVC, or HDPE).

**FOR BURIED APPLICATIONS: Valves should be installed such that the center-line of the pipe is a minimum of 18" below grade. We recommend a double valve box, allowing access to the union nuts to facilitate simple future maintenance or repair.**