



6400 Corporate Avenue
Portage, MI 49002
269-323-2495 or 800-374-0234
Fax: 269-323-0630 or 866-879-5982
www.colonialengineering.com

2" HD-SC Series Full Block® True Union Ball Valve / PVC Ball Valve with HDPE Spigot End Connectors

V20101 <u>HD</u> -SC	PVC Valve/EPDM o-rings, with Two HDPE Spigot End Connectors
V20101 <u>HP</u> -SC	PVC Valve/ EPDM o-rings with One HDPE Spigot End Connector, and One PVC Socket End pc, to transition from HDPE to PVC piping.

- SC Series suitable for buried service. Use standard Champion style sprinkler-key with triangle handle, or Lasco Plastic Key Wrench (VALVE KEY 1) to operate (not included).
- Can also be used in standard service by manually turning the operating nut.
- Slo-Close operation with Patented gear-driven operating nut. Turn nut 360° clockwise, and ball will rotate 90° to close valve.
- Prevents shock from the sudden closure of a standard quarter turn ball valve.
- Replaces Gate Valves in irrigation piping systems, as well as other applications.
- Slo-Close valves are to be operated in the Open or Closed position. Do not attempt to meter or throttle in a partially open/closed position.

Climate conditions: PVC valves (and pipe & fittings) are pressure rated at 73 deg F, and must be de-rated as operating temperatures increase. Normally, we are referring to the fluid passing through the system, but in this case, we are also talking about the exterior environment. Once plastic pipe, valves and fittings are in a box and / or down hole, away from direct sunlight, they will be closer to ambient, so they can function at their rated pressure.

During construction, on a day with 85 deg F heat and direct-sun exposure, the surface temps of thermoplastic piping components may reach in excess of 140 deg F. PVC is fully de-rated for pressure at 140 deg, and can start to mal-form at 160 deg. So these components may be damaged and unusable after reaching this rate of heat.

The benefits of using a PVC Slo-Close valve and HDPE piping components (complete corrosion resistance and avoidance of water hammer, ease of installation) can be attained if the installing contractor takes care during construction to:

- **Avoid storing them in direct sunlight or very hot areas.**
- **Avoid leaving them exposed to sunlight in open trenches**
- **Allow the valves, pipe and fittings to cool and settle before pressurizing them with water.**
- **Re-check the tightness of the union nuts prior to pressurizing the system.**

These recommendations apply to any thermoplastic pipe, valves & fittings (PVC, or HDPE).

OPERATION, INSTALLATION, & MAINTENANCE INSTRUCTIONS

BURIAL DEPTH: Valves should be installed such that the center-line of the pipe is a minimum of 18" below grade. We recommend a double valve box, allowing access to the union nuts to facilitate simple future maintenance or repair.

Operation: Rotate handle slowly 360° clockwise to close, 360° counter-clockwise to open. Do not attempt to turn past the stops. Handle can be turned manually or by use of key wrench for direct buried service. Cycle time to open, 5-10 seconds, cycle time to close, 3-5 seconds.

Prior to Installation:

PLEASE READ THE FOLLOWING INFORMATION PRIOR TO INSTALLING AND USING COLONIAL VALVE VALVES, STRAINERS, FILTERS, AND OTHER ASSOCIATED PRODUCTS. FAILURE TO FOLLOW THESE INSTRUCTIONS MAY RESULT IN SERIOUS INJURY.

1. Colonial Valve guarantees its products against defects in material and workmanship only. Colonial Valve assumes no responsibility for damage or injury resulting from improper installation, misapplication, or misuse of any product.
2. Colonial Valve assumes no responsibility for damage or injury resulting from chemical incompatibility between its products and the process fluids to which they are subjected. Compatibility charts provided in Colonial Valve literature are based on ambient temperatures of 70°F and are for reference only. Customer should always test to determine application correctness.
3. Consult Colonial Valve literature to determine operating pressure and temperature limitations before installing any Colonial Valve product. Note that the maximum recommended fluid velocity through any Colonial Valve product is five feet per second. Higher flow rates can result in possible damage due to water hammer effect. Also note that maximum operating pressure is dependent upon material selection as well as operating temperature.
4. Colonial Valve products are designed primarily for use with non-compressible liquids. They should NEVER be used or tested with compressible fluids such as compressed air or gas.
5. Temperature effect on piping systems should always be considered when the systems are initially designed. Piping systems are required to be designed and supported to prevent excess mechanical loading on Colonial Valve equipment due to system misalignment, shock, vibration, weight, and the effects of thermal expansion and contraction.
6. Trench depth is also an important consideration in freezing climates. Installing the pipe deeper gives it more protection against frost. Where possible, all the pipe, valves and fittings should be installed below the soil frost line.

VALVE ASSEMBLY, AND JOINING WITH HDPE PIPE:

First, assemble HDPE Spigot Ends to valve. Be sure that the union nuts are properly tightened. Spigot ends should be seated against face o-rings of valve body. To check for tightness, make sure they cannot turn or rotate, but are in a fixed position.

After joining the Spigot Ends to the valve, place the valve body in position. Be sure that the valve is installed in the proper direction, per the Flow-arrow indicated on the valve body. Spigot ends are to be joined to HDPE electro-fusion fittings, or compression adapters, following equipment manufacturers' recommendations. This valve is not suitable for butt fusion in a section of HDPE pipe that exceeds 24" in length due to thermal expansion and contraction of HDPE. They are designed to connect to a directional-changing fitting. NOTE: After joining the sub-assembly with the lateral connections, re-check the union nuts so they are properly tightened.

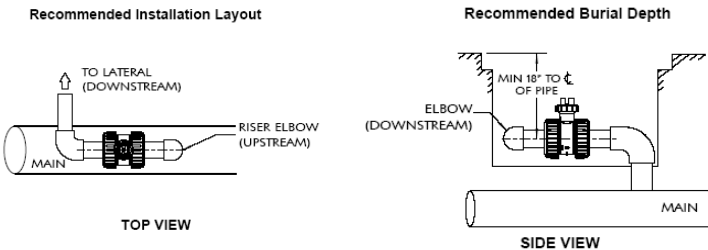
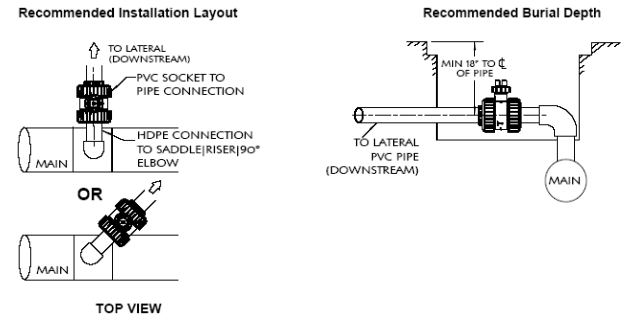
Layout for assembly where downstream piping is HDPE (HD-SC) :**Layout for assembly where downstream piping is PVC (HP-SC) :****Using Union Nuts:**

Be sure that face o-rings are properly seated and mating with the end-connectors prior to tightening union nuts. The face of the end connector must be squarely aligned with valve body and must fit flush against the o-ring seal. NOTE: DO NOT USE THE UNION NUT TO DRAW TOGETHER ANY GAPS BETWEEN THE END CONNECTOR AND THE O-RING OR VALVE BODY.

Valve should be in the OPEN position when tightening union nuts. Install with FLOW ARROW in proper orientation.

Tighten union nuts with the valve in the OPEN position. It is mandatory to avoid the misalignment of the mating pipes, as this can cause excess stress on the valve, and can create a false "hand-tight" condition. With proper alignment, all union nut connections for 1/2"-2" plastic valves should be "hand-tight". For valves 2" and larger, a strap wrench or approved union-nut wrench may be used to tighten the nut 1/10th turn maximum past hand-tight.

Care should be taken to keep the body threads and the internal threads of the union nuts clean. If dirt is present, the threads should be rinsed with clean water to facilitate tightening

PVC JOINTS:

For PVC End pieces, solvent weld socket connections per Cement / Primer manufacturers' recommendations. Do not allow cement to enter the ball & seat area (waterway of the valve).

SOCKET CONNECTION:

Socket end connections are manufactured to ASTM D2467-94. Solvent cementing of socket end connections to pipe should be performed per ASTM specifications D2855-87. Cut pipe square. Chamfer and deburr pipe. Surfaces must be cleaned and free of moisture, oil, dirt and other foreign material. Apply primer to inside socket surface of end connection. Never allow primer or cement to contact valve ball or seat sealing surfaces, as leaking may result. Use a scrubbing motion. Repeat applications may be necessary to soften the surface of the socket. Next, liberally apply primer to the male end of the pipe to the length of the socket depth. Without delay, apply cement to the pipe while the surface is still wet with primer. Next apply cement lightly, but uniformly to the inside of the socket. Apply a second coat of cement to the pipe, and then join the valve socket to the pipe, rotating 1/4 turn in one direction as it is slipped to full depth of the socket. HOLD in this position for approx. 30 seconds to allow the connection to "set". After assembly wipe off excess cement. Full set time is a minimum of 30 minutes at 60 to 100° F. CONSULT PRIMER AND CEMENT MANUFACTURER'S INSTRUCTIONS TO VERIFY PROPER SET AND CURE TIME.

THREADED CONNECTION:

Threaded end connections are manufactured to ASTM specifications D2464, F437 and ANSI B1.20.1. Due to the variable quality and tolerances of plastic male threaded nipples, Colonial no longer recommends the use of PTFE (Teflon®) tape. **We recommend using the following thread sealant: IPS WELD-ON All Seal™.** To provide a leak proof joint, the pipe should be threaded into the end connection "hand tight". A strap wrench may be used to tighten the joint an additional 1/2 turn past hand tight. Tightening beyond this point may induce excessive stress that could cause failure.

ADJUSTMENT FOR SEAT WEAR:

CAUTION MUST BE TAKEN WHEN WORKING ON THIS VALVE. THE PIPING SYSTEM MUST BE DEPRESSURIZED. PROPER CARE MUST BE TAKEN. CONSULT M.S.D.S. (MATERIAL SAFETY DATA SHEETS) INFORMATION REGARDING YOUR SPECIFIC APPLICATION.

In the event that a leak occurs from seat wear, there is no need to remove the valve cartridge from the system. Make sure the system is de-pressurized. With the valve in place, simply close it, and then re-tighten the union nut on the upstream side (the side of the body featuring the word "ADJUST"). This will increase the load of the carrier on the ball, to compensate for seat wear. **Remember: All union nut connections for plastic valves should be "hand-tight". If further tightening is deemed necessary, a strap wrench or approved union-nut wrench may be used to tighten the nut 1/10th turn past hand tight.**

TO DISASSEMBLE FOR MAINTENANCE: Depressurize and drain the system. Remove union nuts and remove cartridge. Open the valve. Pull the locking strip on the "ADJUST" side of the valve. Close the valve. Push out the carrier by pressing on the ball from the opposite side. With the carrier removed, you have access to the seats. The stem can also be removed at this time, after removing the handle. A complete line of repair parts is available.