

Spring Check valves are used to prevent back-flow and siphoning. The 1/2 lb. SS spring maintains a positive seal even when no backpressure is present.

Suggested applications: pool/spa assemblies and installations, potable water systems.

FEATURES AND BENEFITS

- 2-psi minimum flow pressure required to open valve
- Pressure rating: 150 psi, non-shock water at 73° F
- Flow direction indicator molded into body for accurate installation
- 304 SS spring for corrosion resistance
- 1/2 - 2" socket (solvent weld) end connections
- Corrosion-resistant PVC body with EPDM seal
- Low-cost operation

Note: For Foot Valve requirements, see the Colonial Single Union ball check valve.

SAMPLE ENGINEERING SPECIFICATION

Thermoplastic spring check valves shall be constructed from PVC Type I, cell class 12454 material conforming to ASTM D-1784. Seal shall be EPDM. Valves shall have socket end connectors for solvent weld installation. All 1/2 - 2" valves shall be pressure rated at 150 psi, non-shock water at 73° F.



**TEMPERATURE CORRECTION
FACTORS FOR VALVES & UNIONS
(ABOVE 73° F)**

Temp (° F)	PVC
73	1.00
80	.88
90	.75
100	.62
110	.50
120	.40
130	.30
140	.22
150	NR
160	NR
170	NR
180	NR
200	NR
210	NR
240	NR
280	NR

NR: Not Recommended

Caution: Colonial recommends a minimum installation distance of 10 X the pipe diameter from a pump or other sources of turbulence.

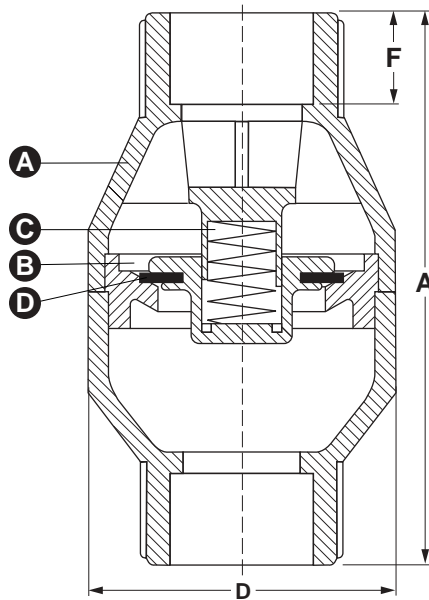

COMPONENTS AND MATERIALS

Part Letter	Component	Quantity	Material
A	Body	1	PVC
B	Connector Seat	1	PVC
C	Spring	1	304 SS
D	Seal	1	EPDM

DIMENSIONS

Part No.	Size	A	D	F
V07221B	1/2"	4-1/8"	2-7/32"	11/16"
V08221B	3/4"	4-1/8"	2-7/32"	23/32"
V10221B	1"	5-1/4"	2-7/8"	7/8"
V14221B	1-1/4"	5-15/16"	3-19/32"	1-5/16"
V17221B	1-1/2"	5-15/16"	3-19/32"	1-1/16"
V20221B	2"	7"	4-7/32"	1-5/32"

⚠

**COMPRESSED
AIR WARNING**

The products in this document are only intended for use in transferring or storing chemically compatible pressurized liquids. **Do not test or use products in this document with compressed air or other gases.** Doing so is dangerous and could cause injury or great bodily harm should a system fail under compressed air. Only use products that are specifically designed for compressed air/gas service. Call Colonial technical service for more information.